

ULTRASONIC INTELLIGENT SENSORS

# ClampOn DSP-06 Subsea Particle Monitor

DIGITAL SIGNAL PROCESSING



ULTRASONIC INTELLIGENT SENSORS

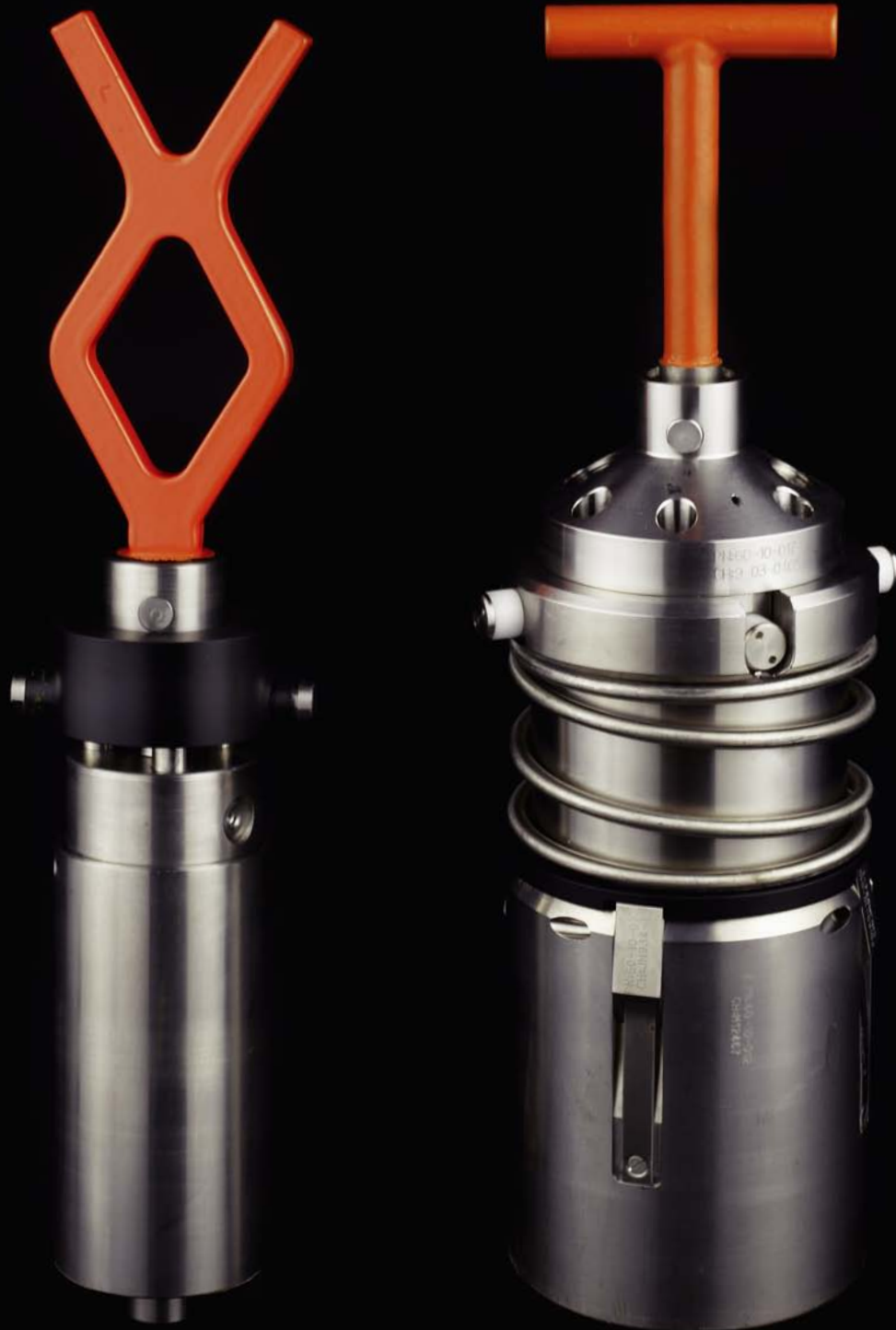

# Why choose a ClampOn DSP-06 Subsea Particle Monitor?

Sand production in Oil and Gas wells is one of the most challenging factors an operator faces during production. Going subsea, safety issues in conjunction with the need to produce as much as possible per well, makes the selection of a subsea monitoring system even more important.

The ClampOn subsea sensors are designed to meet these requirements:

- Designed for a service life of more than 25 years
- Independent redundant electronics
- Independent high and atmosphere pressure chambers
- Electron beam (EB) welding of the chamber against external pressure (no rubber or mechanical seals)
- Glass-metal penetrator as a barrier between high and atmosphere pressure chambers
- Outstanding sensitivity, repeatability, accuracy and signal/noise ratio thanks to Digital Signal Processing (DSP-06)

The history behind the ClampOn Subsea Systems started in 1996 in close collaboration with Shell Deepwater Development Inc. in Houston and FMC Technologies in Norway. The successful outcome of the project was a subsea sand monitoring system that combined an extremely long working life with excellent acoustic properties, offering reliability in the high-pressure deep-water environment. Since then, ClampOn has supplied close to 90% of the acoustic subsea sensors to the global market and its products are recognized as the industry standard in this field. Product development has been a continuous process for many years as we strive to enhance the performance of our subsea systems in order to meet new requirements and offer the market the very best technology.

The latest development to be incorporated in our systems is the DSP-06 filtering technique that represents a huge leap in technology ahead of alternative solutions.

If safety issues, profitable production, service life and system performance matter, then the ClampOn DSP-06 Subsea Particle Monitor is your natural choice!

*Picture showing the ClampOn deepwater and the compact sensors.*

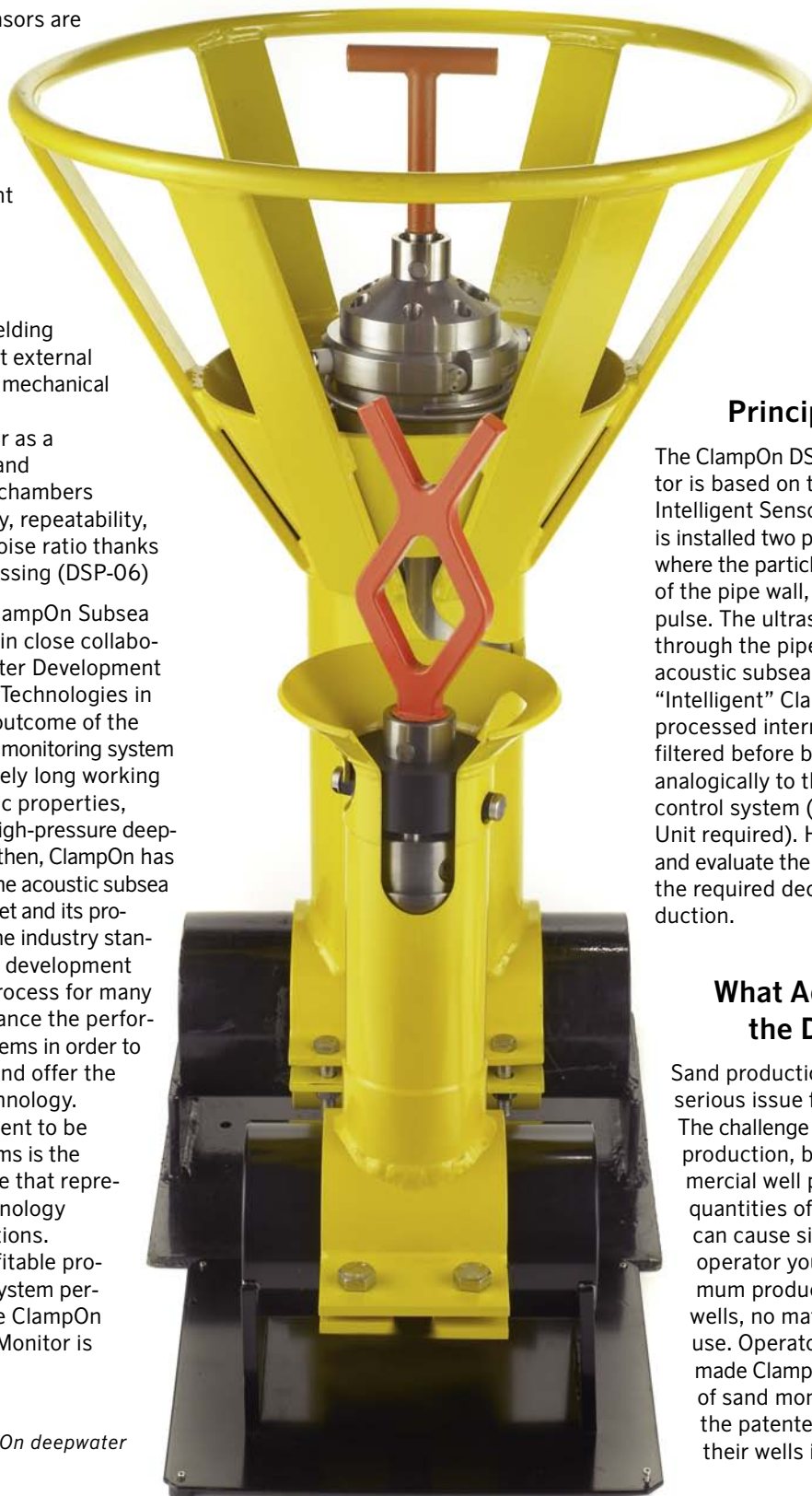

## Principle of operation

The ClampOn DSP-06 Subsea Particle Monitor is based on the ClampOn “Ultrasonic Intelligent Sensor” technology. The sensor is installed two pipe diameters after a bend, where the particles/solids impact the inside of the pipe wall, generating an ultrasonic pulse. The ultrasonic signal is transmitted through the pipe wall and picked up by the acoustic subsea sensor. In the patented “Intelligent” ClampOn sensor the signal is processed internally by a DSP engine and filtered before being sent digitally and/or analogically to the topside computer or control system (no Calculating Interface Unit required). Here the user can monitor and evaluate the data in real time and make the required decisions for profitable production.

## What Advantages does the DSP-06 offer?

Sand production in oil and gas wells is a serious issue for oil and gas producers. The challenge is not merely to avoid sand production, but also to increase commercial well productivity, as even small quantities of particles in the well flow can cause significant damage. As an operator you are interested in maximum production and profit from your wells, no matter what technology you use. Operators all over the world have made ClampOn their preferred supplier of sand monitoring systems, due to the patented technology that turns their wells into profit generators.

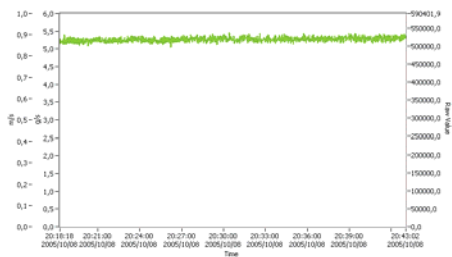

Figure 1. The signal from the sensor on a high flow-rate, high pressure gas well using traditional/alternative sensor without DSP-06 filtering technology.

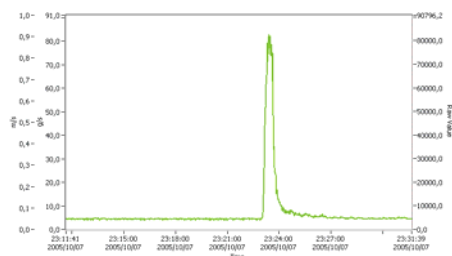

Figure 2. Sensor signal experienced on the same well, now with the new ClampOn DSP-06 filter. This shows how the sensor has completely removed the flow noise, allowing the operator to monitor the true nature of the sand being produced.

The ClampOn DSP-06 model incorporates a new filtering technique that makes the particle monitor an extremely useful tool for analyzing the true nature of sand production, helping to control it and finally, increasing the profit from the well! This filtering technique is the result of integrating our experience of thousands of wells, analyzing data, and using the results to enhance the technology used in our DSP-06 model.

The enormous capacity of the DSP sensor (the only one on the market) makes it possible to scan through a frequency range of 1 MHz 128 times per second. This illustrates the capacity of our technology and of the filtering technique that is at the core of acquiring and processing sand data.

Figure 1 shows a sensor installed close to a choke valve on a gas well operating at high pressure and high velocity. The figures illustrate what the signal looked like when using a traditional/alternative system compared to using the new DSP-06 filtering technology. The new DSP-06 filter (ref. figure 2) was able in this case to reduce unwanted noise by a factor of 500 compared to alternative solutions.

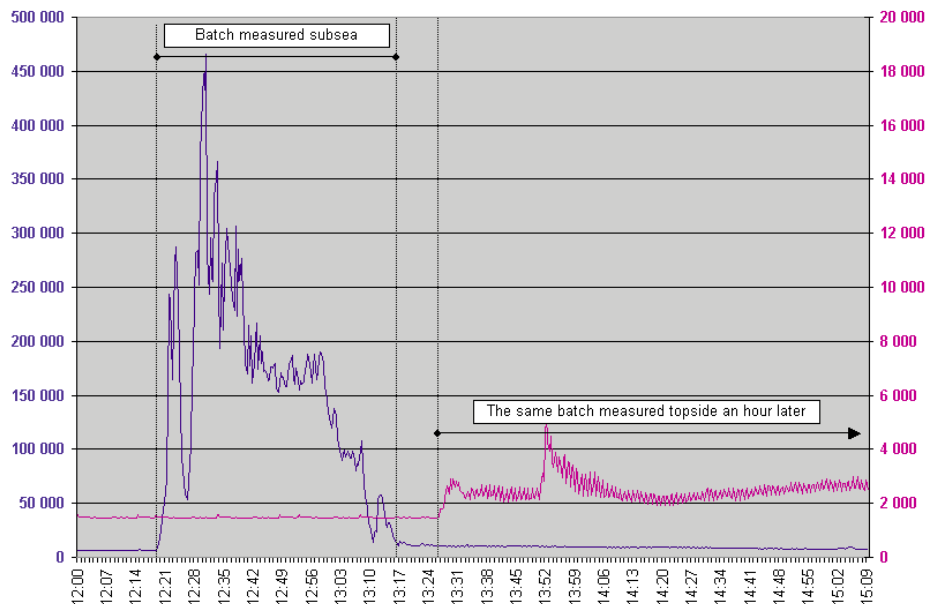
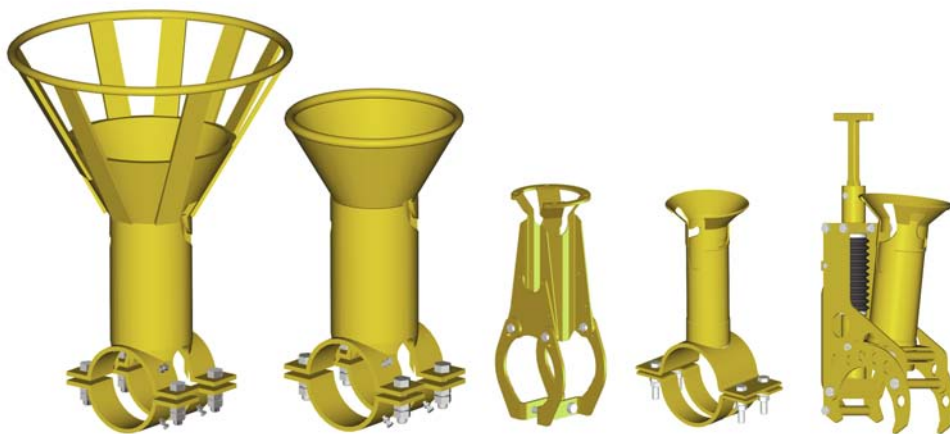

Figure 3 illustrates the difference between raw value signals from a subsea sensor and a topside sensor.

## Why go subsea?

A commonly asked question is why not install the sand monitoring system on the surface as such a solution appears to be cheaper and the operator has easy access to the sensors. On a subsea well, ClampOn would always recommend having the sensor subsea, as the sand signal will be picked up earlier and more strongly than it would be on a topside sensor. Figure 3 shows an example of this. When sand particles travel over a long distance, e.g. to an FPSO, the sand will be dispersed over the total flow line distance. If the sand detector is located subsea, the operator will have the sand production

information available immediately after the sand has passed the subsea tree. If the operator has the sand detector located topside on the same subsea well, he will have to wait until the sand has arrived at the topside facilities before being warned of the presence of sand. The signal will be lower due to dispersal in the subsea line, and if several wells are feeding the same line, the operator will not know which well is producing sand without shutting in the individual wells. There is a greater danger of filling the process equipment with sand, while the operator may not obtain the real-time information he requires about sand production in the well.



Alternative funnels offered by ClampOn.

# ClampOn sand management

When sand is being produced from a reservoir it lowers the production rate and increases maintenance costs; it also represents a serious hazard to its surroundings. Produced sand can never be ignored and any well producing from a sandstone reservoir needs to have some sort of sand monitoring system in place, preferably a real-time sand monitoring system.

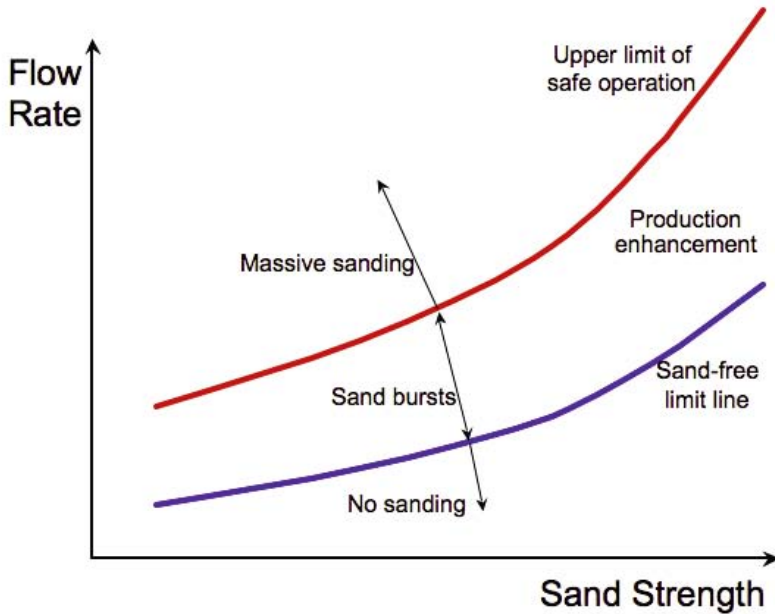

Figure 4 shows what sand management is about. The closer to the red line the operator can produce safely the more profitable the wells become.

In many cases a well is being produced in a conservative manner, at a safe distance below the blue line in an attempt to ensure that sand is never produced. This is a safe but expensive way of managing sand. A more active sand management plan can significantly improve your production statistics. Above the red line continuous sand production is likely, something that should be avoided. The potential for safe increased production and improved earnings lies in the area between the blue and red lines.

There are three main factors when performing sand management – the key words are *prediction, handling and measurement!*

- **Prediction** helps the operator to understand how to produce the well and to manage his sand issues. Sand prediction tools (based on i.e. geological and reservoir data) are useful when designing the facility in order to ensure that it is prepared for any possible sand production when planning a sand management strategy.
- **Sand handling**; produced sand will enter the process system and the operator needs to ensure that it is capable of handling the sand safely. An important

aspect of sand management is reviewing erosion rates and removal issues.

- **Measurement** is a cornerstone of a sand management system. When the prediction and handling issues have been carefully considered, including an understanding of erosion risk and sand removal challenges, a reliable method of measurement is required to ensure that the design criteria are met and not exceeded. This is where the ClampOn DSP-06 Particle Monitor comes in. The sensor's superb sensitivity, filtering mechanism and patented solutions for real-time monitoring combine to make it the best tool available to maintain a profitable and safe sand management program.

ClampOn has been working on the problem of sand production for more than a decade, helping customers all over the world to measure and predict it. Our experience of thousands of wells has given ClampOn unique practical knowledge of how sand production will appear and how it can be measured and dealt with. Over the years ClampOn has had the pleasure of working with many of the best service and research companies involved in sand management.

By combining our knowledge gained from field experience with the ClampOn DSP-06 Particle Monitor and the high level of competence of our partners we are able to offer a unique product. Even for organizations with a high level of expertise, the opportunity to obtain assistance from the world leaders in sand management by making one phone call is invaluable.

## ClampOn – the leading solution to challenges in particle monitoring

A common problem in sand monitoring is interference from signals generated by sources other than particles, such as noise from liquid/gas mixtures, droplets in high-velocity gas wells, mechanical/structural noise, choke noise and electrical interference.

A good signal-to-noise (s/n) ratio is vital to high-quality measurement and the introduction of the DSP-06 model provides operators with absolutely the best s/n ratio available on the market. Figure 5 illustrates clearly the difference between a traditional/alternative system and a ClampOn system. The red line represents a sensor limited by background noise and with an inadequate s/n ratio. In the worst case the sand signal may even drown in the background noise, a hopeless situation from the user's point of view. In high-velocity gas wells, in which liquid droplets collide with the pipe wall at high speed, the red pattern often shows up in flow-sensitive systems. The consequence may well be that the operator reduces produc-



Figure 5. Signal comparison.

# ClampOn's Subsea Philosophy

tion and ruins his own profit goals - even when no sand is being produced.

What is required is a clamp-on sensor that clearly distinguishes sand from other sources of noise, as represented here by the blue line. ClampOn's DSP-06 technology enables the sensor to discriminate background noise so that the pattern of sound made by the sand particles is illustrated clearly on the operator's computer screen. Since ClampOn entered the market in 1995 our system has won all industrial field trials in competition with other systems. The introduction of the DSP-06 model represents a solution that is even less sensitive to background noise and more quantitatively accurate. The ClampOn system's s/n ratio is also very important for an efficient field installation, due to its low calibration costs.

A good signal to noise (s/n) ratio is vital for quality measurements of this sort, and ClampOn's sensors are the very best in this area - a recognition that we are determined to maintain in the future.

## How to determine the maximum sand-free production level of an oil or gas well

All too often, we meet operators who are worried because they are not fully aware of the nature of sand production - so they reduce production unnecessarily. A cutback in production in the range of 20 to 75% is fairly common in oil and gas wells. The superb quality and reliability of the DSP-06 is the logical way to raise production, thanks to the essential data the sensor gives the operator. Bearing in mind the values that sand production limitations represent it is well worth evaluating the ClampOn sand monitoring systems. It is of vital importance to have a system that responds rapidly and accurately to improve sand detection. Usually the operator chokes back production immediately when sand is present (or when he believes sand is present). Figure 6 shows a producing well in which sand production is declining. The curve represents what we call a "GOOD" pattern. As the figure shows, sand is being produced due to the increase in production (opening the choke valve). However by using a reliable sand-monitoring system the operator can monitor the development of sand production. The figure shows how sand production is reduced over time due to consolidation of the producing reservoir. This pattern tells the operator that oil and gas production can continue at this

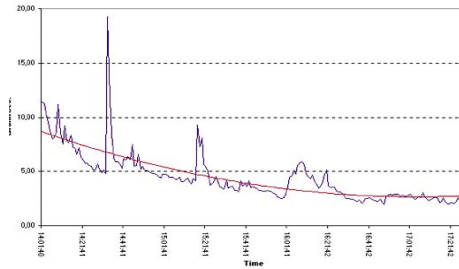

Figure 6. Good pattern.

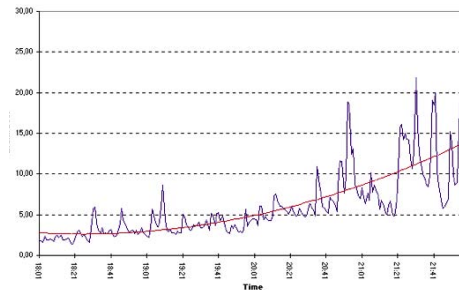

Figure 7. Bad pattern.

level since he will soon have a sand-free well. When the well is finally flowing with no sand production for some time the operator can once again open up the choke and increase production. This will again probably result in sand production, as the figure shows; however, the operator should let the production continue in order to observe the trend in sand production. We are looking for a "GOOD" pattern as shown here. When this curve appears after a time, the operator has a consolidated reservoir.

This method of increasing production takes some time (usually a couple of days) until the operator sees the opposite "BAD" pattern, which shows that sand production is increasing. When the "BAD" pattern appears on the screen the operator restricts production by returning to the previous setting of the choke valve. This tells him the maximum sand-free level of the well. The well is then produced over a period of at least 24 hours to ensure that the formation is consolidated and stable. To achieve effective and safe sand free (or tolerable) rate the operator needs the best monitoring equipment that is available. ClampOn offers that solution together with our experience from thousands of wells!

Picture showing the compact sensor and a funnel.

Subsea operating conditions, and in particular deepwater environments, demand technical solutions that combine flexibility with high performance and extremely long service life. In our case, we must combine such issues as safety, demands for profitable production, lifetime and performance of the system with practical and safe operation in the field. Subsea instrumentation should:

- provide a very long working life, meaning high/low pressure chambers using EB welding to eliminate leaking gaskets/sealing.
- include independent redundant electronics
- be capable of being retrofitted and of being installed and retrieved by ROV
- perform real-time monitoring
- utilize DSP-06 (Digital Signal Processing) technology
- incorporate two-way communication
- permit new software downloads from the user's system
- include self-testing/health check of the sensor unit

(Continued on the next page)



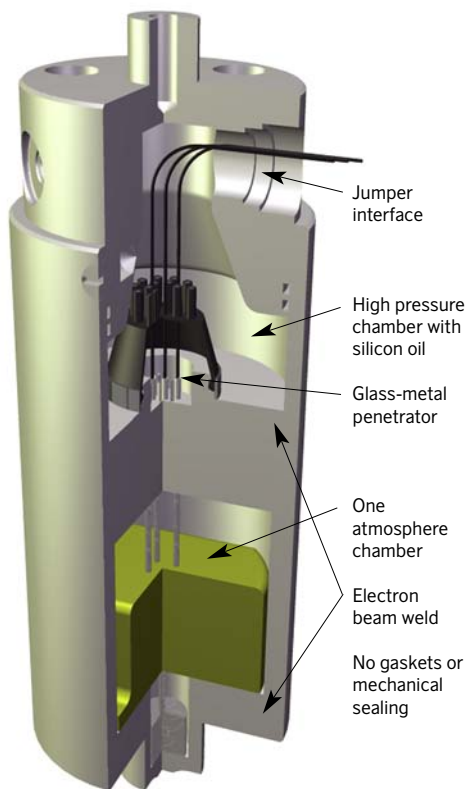

Cross section of a subsea sensor, showing the two chambers and the glass-metal penetrator.

These are the specifications that ensure a long service life for your sand monitoring system! Some of our customers have saved hundreds of million USD by choosing our unique design and quality – the losses involved in cutting corners are unfortunately just as great!

### SENSOR HOUSING

The Deepwater monitor consists of a housing designed by FMC Technologies, which is capable of withstanding depths to 4,500 meters (14,759 ft) without gaskets. The unit is hermetically sealed (welded), with the independent redundant electronics in a one-atmosphere chamber. The one-atmosphere chamber is connected to the high-pressure chamber (filled with silicon oil) by a glass-metal penetrator. The oil-filled high-pressure chamber includes a cavity in the sensor unit, which also is pressure-compensated, meaning there is no differential pressure between the seawater and the oil-filled volume. This reduces the possibility for leakage. Silicon oil is dielectric and can not short-circuit the signal/power cables, and is also less aggressive than seawater when it comes to material corrosion. The chambers have been electron beam-welded to avoid leaking gaskets. The system represents an industry standard that has been subjected to very severe qualification tests for shock, vibration, tempera-

ture and pressure, water tightness, subsea operability, etc., and has come through with flying colors. The Compact Subsea Monitor is a lighter model designed according to the same strict criteria, for operation at depths up to 2,500 meters (8,759 ft). The ROV versions include a retrofit solution for installation on existing fields. Titanium has been selected for both versions in order to avoid the necessity for cathodic protection, which would have been difficult to achieve for an ROV-installed sensor. The use of titanium also reduces the weight and cost of the sensor.

### FUNNELS

The sensor needs to be mounted in a funnel that secures the installation and the performance of the sensor during the operation. A crucial issue here is the risk of heat loss in the area where the sensor is installed. ClampOn's funnels are designed for easy access and good insulation, reducing heat loss to an absolute minimum.

### ELECTRONICS

ClampOn offers two types of subsea sensors; the Deepwater and the Compact Subsea. Both sensors are available with 100% redundancy, meaning fully independent dual electronics, to guarantee a long life cycle under conditions which would make intervention extremely expensive, if not impossible. The design allows for two-way communication between the sensor and user for data transfer and trouble-shooting/functionality testing,

as well as for the possibility of downloading new sensor software versions from the client's control module on the surface.

### INTELLIGENT SENSOR

The intelligence in the sensor means that signal processing is performed in the sensor itself, and the quality of the contact between the sensor and the pipe surface can be measured. This allows the operator to test the complete loop from the topside control module to the sensor itself. Optional functions are also available for measuring vibration as well as temperature on the pipe surface and inside the sensor electronics. ClampOn's DSP technology includes self-testing of the following parameters: input level, RAM, internal voltage, internal temperatures, all internal buses and the sensor element. The system offers users the possibility of downloading new software releases into the sensor. As time goes by, more intelligent and improved software versions will be developed and released. These can be downloaded to upgrade existing installations.

### WHAT OPTIONS DO YOU HAVE?

ClampOn has the largest portfolio of sand detectors available with several different models for both topside and subsea installation. For its subsea systems, ClampOn makes two main versions with a variety of options, depending on depth and functional requirements. The flexibility of ClampOn's systems offers the market the best possible combination of technology and economy.

## Configuration

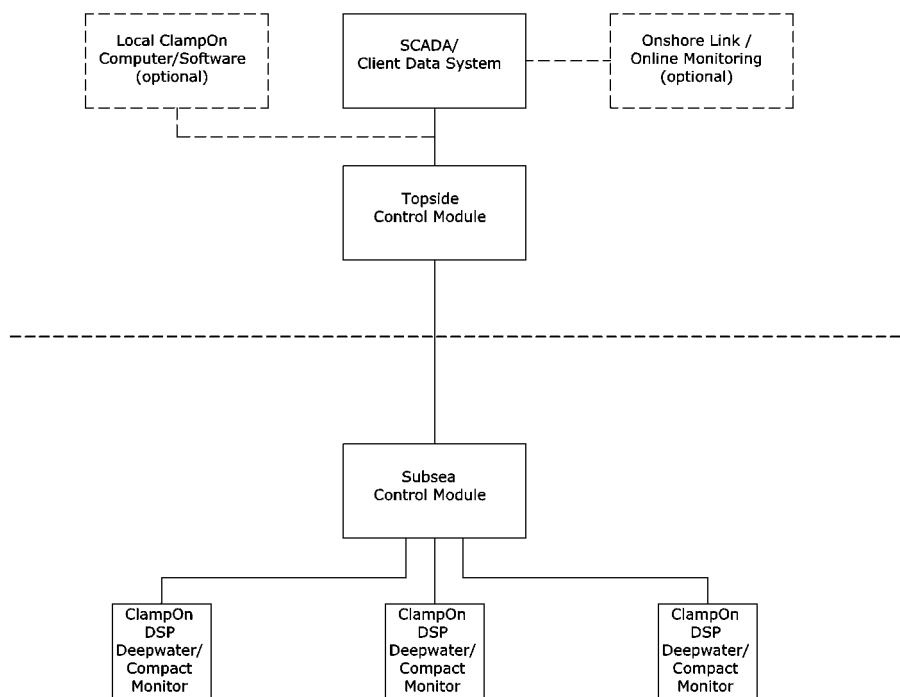

# Product specifications

## PARTICLE MONITOR

Principle of operation	Passive acoustics, intelligent sensor
Minimum particle size	Depends on flow velocity and conditions. Typical sizes are: Oil/water: 25 microns / 1PPM Air/gas: 15 microns / 1 PPM
Minimum sand rate	0,01 g/s
Uncertainty	Topside: ±5% (with calibration by means of sand injections)
Repeatability	Better than 1%
Method of installation	Clamped to pipe surface, non-intrusive
Sensor electronics	Intelligent DSP electronics with signal processing
Interface options	All sensors can be supplied with: Digital RS485 (ASCII, binary, ModBus RTU), 4-20mA (active/passive). Options: CANBus, Profibus
Two-way communication	Yes
Software upgrading	Yes
Pipe Surface Temperature	-40 to 225 °C (-40 to 437 °F)
Flow regimes	Oil, gas, water, multiphase
Diagnostic features	Intelligent health-test of electronic hardware

## SUBSEA PARTICLE

	COMPACT	DEEPWATER
Water depth	3000m	4500m
Max. operating pressure barA	300 (4351psi)	450 (6526psi)
Max. test pressure barA	333 (4829psi)	675 (9790psi)
Housing material	Titanium	Titanium
Dimensions excl. ROV handle	ø90 x 324mm (ø3.5" x 12.8")	ø150 x 359mm (ø5.9" x 14.1")
Dry weight, kg (lbs)	5.2 (11.5)	15.0 (33.1)
Hose/jumper interface	Bennex or ODI	Bennex or ODI
Independent redundant electronics/single electronic	Yes	Yes
Gasket / sealing	No	No
EB welding	Yes	Yes
Glass-metal penetrator	Yes	Yes
Atmosphere pressure/high pressure chamber	Yes	Yes
ROV installation/retrieval	Yes	Yes
Retrofit clamp/funnel	Yes	No
Power Supply	12-28VDC	12-28VDC
Current draw	Approx. 70mA @ 24VDC	Approx. 70mA @ 24VDC
Design Lifetime (MTBF)	220 000 hours (25 years)	220 000 hours (25 years)
Puls function/vibration/temperature measurement	Optional	Optional

## COMPUTER (Optional)

Minimum hardware	Pentium III (or equivalent) with 512 MB RAM
Software requirements for ClampOn's software	Windows™ 2000/2003/XP/NT 4
Input	Modbus Serial/TCP/IP, OPC
Signal output	Modbus Serial/TCP/IP, 4-20mA, Relay, Client Server

# ClampOn - the leader in sand, pig and corrosion-erosion monitoring

ClampOn has since the beginning in 1994 grown to be the largest supplier of passive ultrasonic systems for sand/particle monitoring to the international oil and gas sector. All products supplied by ClampOn, particle monitor, pig detector, corrosion-erosion monitor and leak monitor are based on the same, well proven technology platform. Both the topside and the subsea instruments incorporate Digital Signal Processing (DSP), complete digitalization eliminating analogue filters, circuits and amplifiers.

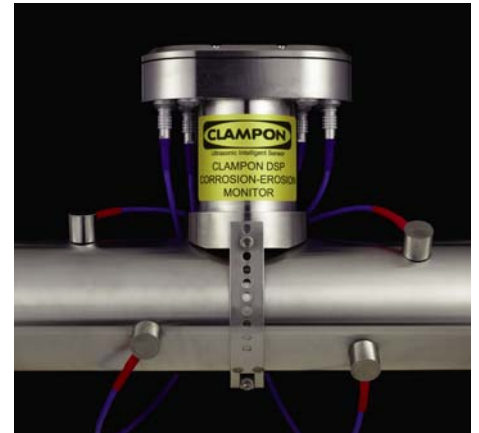

The ClampOn Ultrasonic Intelligent Sensor processes all data in the sensor itself (patented principle), thus enabling the instrument to discriminate between sand-generated and flow-generated noise. This is of importance to the user since changes in flow rates and the gas/oil ratio will not affect the performance of the system.

A good signal to noise (s/n) ratio is vital for quality measurements of this sort, and ClampOn's sensors are the very best in this respect. With the new version, the external noise has been completely eliminated.

The sensors has memory capacity for storing up to 60 days of data, and can even be reprogrammed between being a sand monitor, a pig detector or a corrosion-erosion monitor for monitoring of changes in wall thickness.

## ClampOn DSP-06 Particle Monitor

All sensors are exactly alike and interchangeable, an advantage if sensors should be moved/relocated or in case of service.

The DSP's increase in processing capacity enables the sensor to combine signals from several frequency ranges when analysing the flow. The ClampOn sensors are versatile, and are the only instruments on the market offering two-way communication between sensor and control system. This solution enables future upgrade of the sensor by a simple download of new software. When using digital output from the sensors, they can be installed in a "multi-drop" system. The sensor is installed after a bend, where the particles (chalk or sand) are forced out of the flow and hit the inside of the pipe wall, generating an ultrasonic pulse. The ultrasonic signal is transmitted through the pipe wall and picked up by the acoustic sensor itself.

## ClampOn DSP Pig Detector

The ClampOn DSP Pig detector is a Non-invasive pig detection system designed to be a first stage alarm system for pig detection providing accurate and reliable registration of the time when pigs is passing, and trans-

mits the signal to the operator. The detector can also indicate the amount of debris following the pig during cleaning operations.

## ClampOn DSP Corrosion-Erosion Monitor (CEM)

The CEM is monitoring any changes in wall thickness. Two to eight transducers are glued onto the surface of the pipe (or other metal plate structure) and connected to a clamp-on control unit. The control unit will continuously send and receive guided waves between the transducers, resulting in a network of measurement paths that cover the selected area.

The working principle of the instrument is based on transmitting ultrasonic signals that propagate through the pipe material. The transmitted signal is received by a sensor and is analyzed using advanced data processing schemes.



ISO 9001 CERTIFIED COMPANY



ULTRASONIC INTELLIGENT SENSORS



**NORWAY:** ClampOn AS, Damsgaardsvn. 131, N-5162 Laksevaag, Bergen, Norway, Phone: +47 5594 8850, Fax: +47 5594 8855, e-mail: mail@clampon.com - **USA:** ClampOn, Inc., 15720 Park Row, Ste. 300 (77084), PO Box 219206 (77218-9206), Houston, TX, USA, Phone: +1 281 492 9805, Fax: +1 281 492 9810, e-mail: info@clamponinc.com - **WEB:** www.clampon.com